

80S/T180/BL/M/LHD/E27

Cod. 019485 -

Portalampane monocorpo liscio

One-piece lampholder with plain outer shell

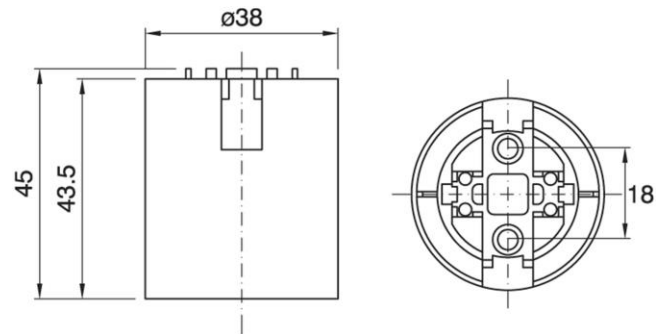
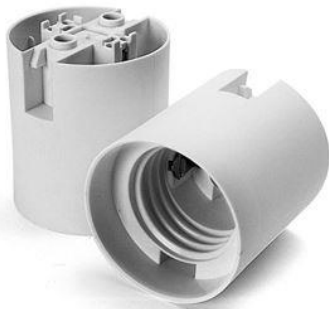

Varianti – Variants

Cod. 019484 - bianco T180°C / white T180°C

Cod. 019489 - nero T210°C / black T210°C

Cod. 019487 - bianco T210°C / white T210°C

Cod. 019490 - oro T210°C / gold T210°C

Cod. 019485

Materiale	Material	termoplastico / thermoplastic resin
Attacco lampada	Lamp socket	E27
Corrente nominale	Rated current	4A
Tensione nominale	Rated voltage	250V
Temperatura nominale	Marking temperature	180°C
Trattamento/Colore	Color/Treatment	nero / black
Categoria sovratensione	Overvoltage category	II
Tipo e sezione cavi	Type and cable cross sections	rigidi o flessibili con sezione da 0.5-2.5 mm ² / rigid or flexible cable with cross-section 0.5-2.5 mm ²
Morsetti	Terminals	automatici / spring type
Fissaggio/Connessione	Fixing/connection	con fori passanti per viti M4 o cappelli a scatto serie 100 / through holes for M4 screws or snap-on domes 100 series
Peso pezzo	Item weight	16,8 g.
Pz. per confezione	Pieces per unit	500
Dimensione confezione	Size of packaging	40 x 38,5 x 29 cm



ITA
Documentazione online
- [LINK PAGINA PRODOTTO](#) -



ENG
Online documents
- [WEBPAGE LINK](#) -

80S/T180/BL/M/LHD/E27

Cod. 019485 -

ARDITI nell'ambito della normativa tecnica adottata, si riserva il diritto di apportare (in ogni momento e senza obbligo di preavviso) tutte le modifiche che, a proprio insindacabile giudizio, ritenesse opportune per migliorare la funzionalità e le prestazioni dei prodotti, nonché per rispondere a proprie esigenze tecnologiche e produttive. / *Within the framework of the adopted technical standards, ARDITI reserves the right to make all those changes (at any time and without prior notice) that, in its final judgement, are needed to improve the functions and performances of the products, as well as to meet the company's technological and production requirements.*