

# 300/V/1/M/T M BL SWITCH

Cod. 028321-

## Interruttore rompifilo unipolare con morsetto di terra

Single-pole rocker switch with earth terminal

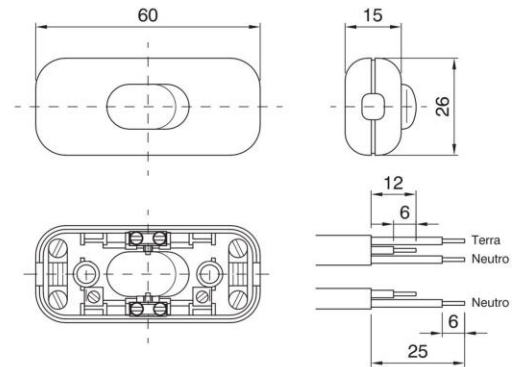

Varianti – Variants

Cod. 028320 - bianco / white

Cod. 029498 - trasparente / transparent

Cod. 028321

Materiale	Material	termoplastico / thermoplastic resin
Tensione nominale	Rated voltage	250V
Carico resistivo	Resistive load	2A
Carico induttivo	Resistive-motor load	1A
Carico lampada	Tungsten lamp load	1A
Trattamento/Colore	Color/Treatment	nero / black
Tipo e sezione cavi	Type and cross sections	piatti bipolari H03VVH2-F 2x0,75 mm <sup>2</sup>   tondi bipolari H03VV-F 2x0.75 mm <sup>2</sup>   tondi tripolari H03VV-F 3G 0.75 mm <sup>2</sup> (G=conduttore di messa a terra) / two poles flat cable H03VVH2-F 2x0,75 mm <sup>2</sup>   two poles round cable H03VV-F 2x0.75 mm <sup>2</sup>   three poles round cable H03VV-F 3G 0.75 mm <sup>2</sup> (G=ground conductor)
Presenza morsetto di terra	Earth Terminal	Sì / Yes
Dimensioni	Dimensions	60 x 26 x 15 mm
Tipologia morsetti	Terminals	a vite / screw type
Peso pezzo	Item weight	20,9 g.
Pz. per confezione	Pieces per unit	1000
Dimensione confezione	Size of packaging	52 x 39 x 30 cm



ITA  
Documentazione online  
- [LINK PAGINA PRODOTTO](#) -



ENG  
Online documents  
- [WEBPAGE LINK](#) -

# 300/V/1/M/T M BL SWITCH

Cod. 028321-

ARDITI nell'ambito della normativa tecnica adottata, si riserva il diritto di apportare (in ogni momento e senza obbligo di preavviso) tutte le modifiche che, a proprio insindacabile giudizio, ritenesse opportune per migliorare la funzionalità e le prestazioni dei prodotti, nonché per rispondere a proprie esigenze tecnologiche e produttive. / *Within the framework of the adopted technical standards, ARDITI reserves the right to make all those changes (at any time and without prior notice) that, in its final judgement, are needed to improve the functions and performances of the products, as well as to meet the company's technological and production requirements.*